

FLEXIBLE HOSE CONNECTION - Water tank

It is a well know fact that the majority of tank failures (including plastic tanks) occur at the tank wall location where a fitting is connected to a tank outlet. Typically this occurs on the lower 1/3 of the tank wall. In the majority of cases the rigidity of a tank's plumbing connection typically does not allow the plastic tank sidewall to expand and contract adequately as it is filled and emptied. This causes a stress point to develop that ultimately becomes the cause of failure at some stage within a tanks service life.

The Customer must strictly follow all installation instructions including but not limited to instructions concerning the fitting of flexible hose from the outlet. Poly pipe, rigid PVC pipe or metal pipe is not a flexible hose. Connect your tank outlet with flexible hose at least 300mm (12") in length. The hose must be placed between the valve and all other plumbing or rigid pipe work. Elbow fittings must be used.

Refer to Bushmans Tank Installation Guide for steps to follow to ensure you do not void your guarantee. Bushmans have available a FLEXIBLE HOSE KIT suitable for both 50mm and 25mm ball valves. A copy of the Guide can be obtained from www.bushmantanks.com.au, on the Information page. You can contact your local Bushmans sales consultant, by phone on 1800 00 88 88, to learn how to obtain our recommended connection kit, which includes a 1,000mm heavy duty flexible PVC hose, elbow fitting and straight couplings.

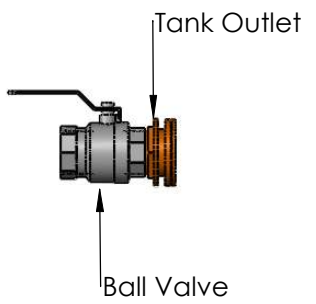
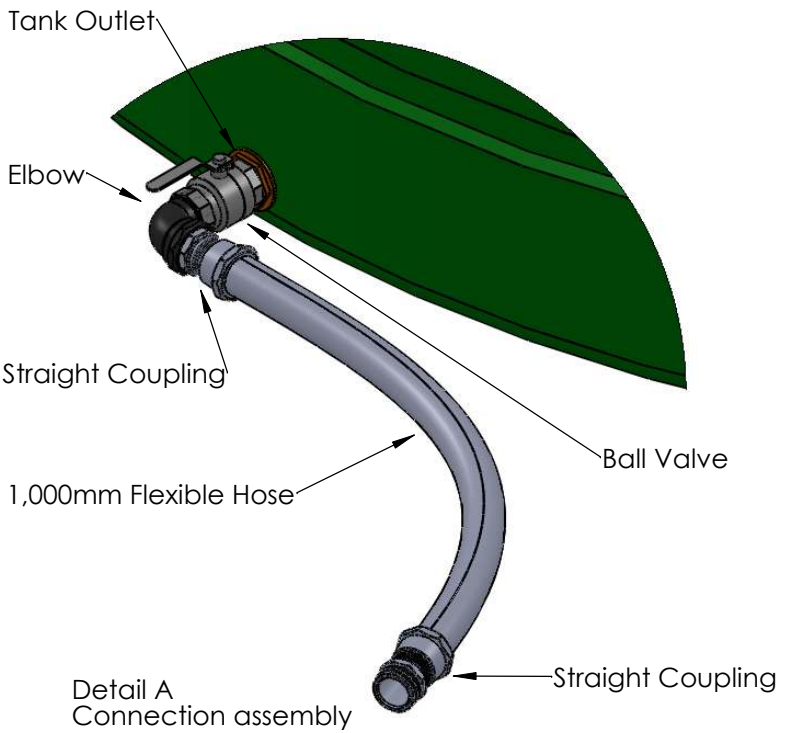
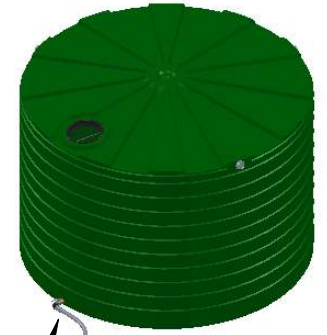
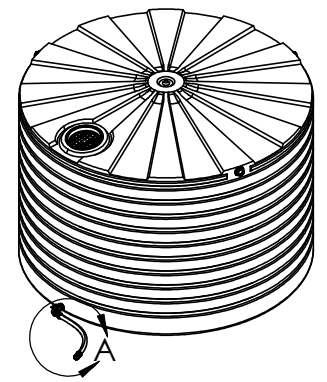

Flexible Hose connection

It is the responsibility of the tank purchaser to install the appropriate flexible connections between the tank and the plumbing. This is important as the Bushmans tank guarantee is only valid if the installation has appropriate flexible connections.

IMPORTANT : Flexible connections substantially reduces stress at tank fitting locations caused by rigid piping and/or vibrations from pumps.

UNLESS OTHERWISE SPECIFIED: DIMENSIONS ARE IN MILLIMETERS		FINISH:		DEBUR AND BREAK SHARP EDGES		DO NOT SCALE DRAWING		REVISION	
SURFACE FINISH:									
TOLERANCES:									
LINEAR:									
ANGULAR:									
DRAWN:		NAME	SIGNATURE	DATE		BUSHMANS GROUP PTY LTD			
CHK'D:		BUSHENG		Dec 2010		TITLE: Flexible Hose Connection for standard water tank			
APP'VD:									
MFG:									
				MATERIAL:		DWG NO. T6500_FLEXMASTER ASSEMBLY2		A2	
						SCALE:1:50		SHEET 1 OF 1	

Refer to Bushmans Tank Installation Guide for steps to follow to ensure you do not void your guarantee. This Installation Guide can be obtained from www.bushmantanks.com.au on the Information page.

You can contact your local Bushmans sales consultant by phone on 1800 00 88 88 to learn how to obtain our recommended connection kit, which includes a 1M long heavy duty flexible PVC hose, 90 degree elbow fitting and straight couplings.

BILL OF MATERIAL					
ITEM	ORDER CODE	QTY.	LENGTH "L"	Description	DIAMETER "D"
	FLEX25KIT	1	1000 mm	FLEXIBLE HOSE KIT - WATER	25 mm
	FLEX50KIT	1	1000 mm	FLEXIBLE HOSE KIT - WATER	50mm
1		1	1000 mm	PVC HEAVY DUTY SUCTION HOSE	25 OR 50 mm
2		2	-	STRAIGHT COUPLING ADAPTOR	25 OR 50 mm
3		1	-	90° ELBOW	25 OR 50 mm

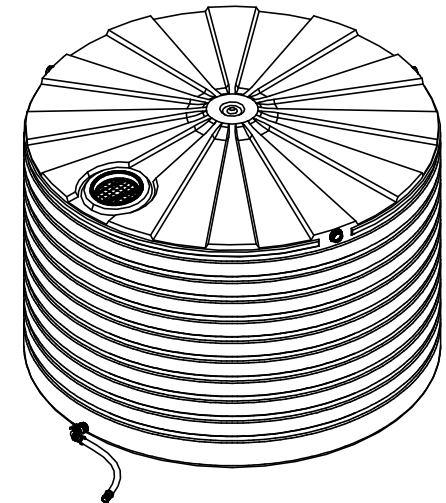
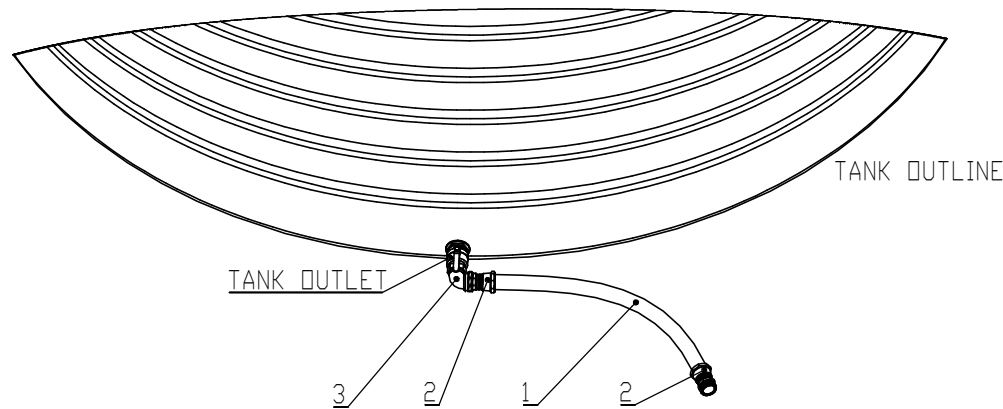
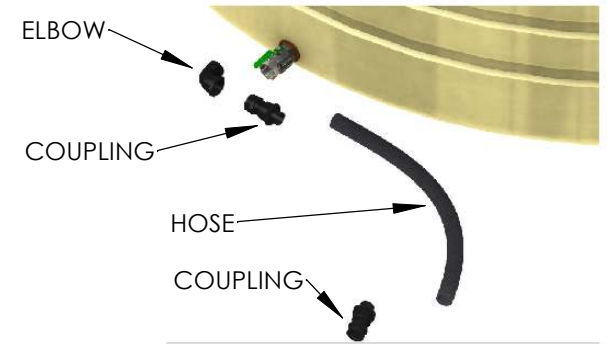
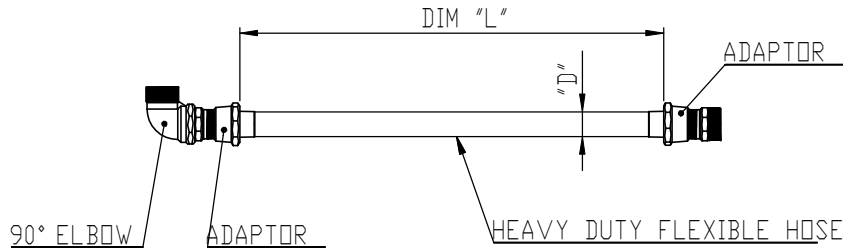

It is the responsibility of the tank purchaser to install the appropriate flexible connections between the tank and the plumbing. This is important as the Bushmans tank guarantee is only valid if the installation has appropriate flexible connections

BUSHMANS GROUP PTY LTD

Level 13, 300 George St, Sydney, NSW 2000 HEAD OFFICE
GPD 4218, NSW, SYDNEY, 2000 WWW.BUSHMANTANKS.COM.AU

Copyright 2011 Bushmans Group Pty Ltd. This drawing may not be reproduced or transmitted in any form or by any means in part or whole without written permission of Bushmans Group Pty Ltd.

Drawn **BUSHENG**
Date **19/01/2011**
Scale **1:50**

Project Title **FLEXIBLE HOSE KIT**
Material
Finish

Drawing Title
**WATER TANK
FLEX HOSE ASSEMBLY KIT**

A3 Size Drawing

Sheet of